

S2E Module - an alternative to PRV to reduce Steam Pressure

S2E Module

STEAM TO ENERGY Transformer

Micro Steam Turbine & Generator Module

Wet Steam Turbine Operation

PLUG and PRODUCE System

S2E Module is an ecologically designed steam micro-turbine module for the utilization of the energy of the working medium, e.g. steam, to be transferred to electric energy. It has a solid steel frame

which enables easy transportation, installation and maintenance without the need of using special tools. The module contains all components for direct connection to the existing distribution system. Connections of the equipment to the mains in accordance with agreed requirements of the customer are also provided.

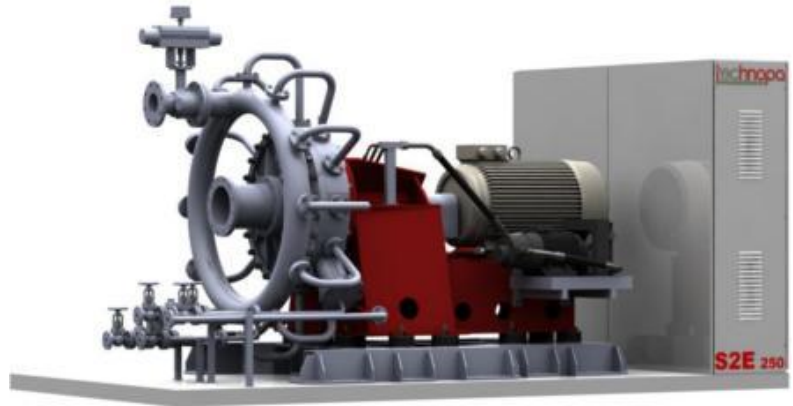

TECHNOPA GmbH, Hietzinger Hauptstr. 50 1130 Vienna, Austria

tel.: +43 1 877 0553 • fax: +43 1 877 8446 • www.technopa.eu • office@technopa.eu

ROTATING REDUCER

The use of S2E module as a rotating reducer is one of its basic application possibilities. It is a substitution of one reducing valve or system of reducing valves in existing systems, e.g. steam system that have reduced the operational parameters of the steam from the supplier to the user according to his requirements. Reduction by system of valves is always associated with loss of great part of the energy and its conversion to heat. Connecting of rotating reducer – S2E module into the system enables utilization of this energy for production of electric energy that can be used for self-consumption, supplying to the grid, or combination of both options.

Technology

Revolutionary concept of the turbine with original and patented design is based on the substitution of turbine blades with system of bristles. Material of bristles, their cross-section, shape and density are precisely defined and they are the result of long-term research and tests at various technical parameters.

Multiple tangential input of working medium on the turbine bristles is optimized by the system of nozzles of own concept that enable optimal conversion of kinetic energy of working medium to the force with efficiency of 95%. According to the measurements, it is an aerodynamic conversion of kinetic energy with minimum

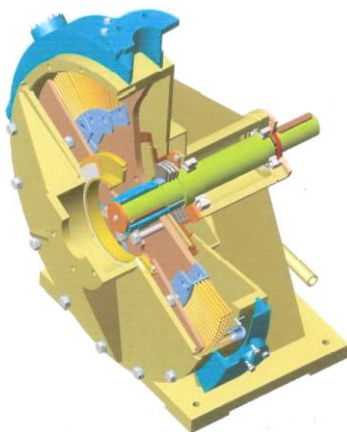

losses by friction and whirling of the working medium. Kinetic energy of the working medium is absorbed in the inlet into the turbine circuit so that for example, at outlet velocity of 800m/sec of the steam from the nozzles, its energy is completely absorbed at 80mm of the length of perimeter of the turbine wheel.

Outlet of the working medium is on Archimedean spiral from the center of the turbine.

Condensate removal is solved by separate sub-circuit in the bottom of the turbine.

Turbine wheel is placed in the system of high-quality bearings made by renowned manufacturers with own lubricating and cooling aggregate that is an inseparable part of each equipment. Strong emphasis is given mainly on balancing of the turbine wheel. Despite the fact that no vibrations have

been found during the tests and operation of individual equipments except the declared parameters, special vibration sensor with on-line output to display of S2E50-250 module is part of each equipment.

Standard solutions of turbine wheel blades are very sensitive to production accuracy and technological discipline, and they often enable utilization only in the areas of limited technical and operational parameters – using in the area of dry steam of IS diagram, turbines operate at high revolutions, complicated system of operation and maintenance, etc. .

Substitution of blades of turbine runner of standard steam turbines by the system of bristles provides the turbine and the operator with new possibilities with excellent technical parameters:

- in addition to standard operational parameters, it can also operate unlike the blade turbines in the mode of so-called wet steam,
- turbine can be operated also during frequent and quick changes of operational parameters,
- turbine can be operated in horizontal or vertical positions,
- turbine regulation is possible from zero to maximum at unchanged efficiency rate,
- turbine operates at low operational revolutions / 3000 rev/min /
- rise time from the “cold status” to maximum is up to 10 min.

TECHNOPA GmbH, Hietzinger Hauptstr. 50 1130 Vienna, Austria

tel.: +43 1 877 0553 • fax: +43 1 877 8446 • www.technopa.eu • office@technopa.eu

Standard Operating Parameters

Characteristics	Specification
Electric Power 50 kWe, 100 kWe, 150 kWe, 200kWe, 250 kWe	50 – 500 kWe
Incoming steam temperature	min 130 C max 350 C
Incoming steam pressure	min 4,0 bar max 20,0 bar
Outcoming steam temperature	min 105 C max 315 C
Outcoming steam pressure	min 1,0 bar max 5,0 bar
Steam flow	min 1,5 t/hour max 10 t/hour

Electric parameters

Characteristics	Specification
Voltage	230 V 480 VAC /400 VAC
Frequency	50 Hz / 60 Hz
Grid-isolated regulation / steady state /	+/- 0,50 % nominal voltage max +/- 0,50 % nominal frequency
Efficiency based on Eff1	96%
Isolation class	IP 55

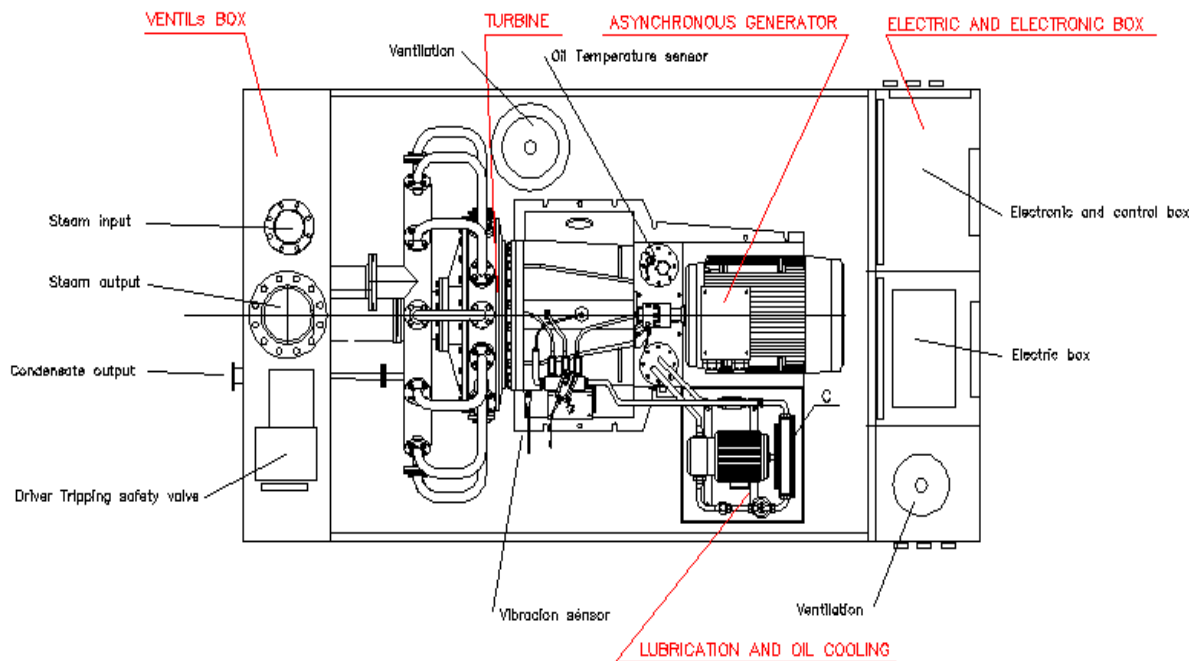

TECHNOPA GmbH, Hietzinger Hauptstr. 50 1130 Vienna, Austria

tel.: +43 1 877 0553 • fax: +43 1 877 8446 • www.technopa.eu • office@technopa.eu

Standard Operating Parameters

Total efficiency of the S2E module - 55%

- The efficiency is calculated from the input and output parameters of steam / thermal work in accordance with Mollier Graph / and output of the electrical power of the generator
- This efficiency includes all the "losses" of the equipment from the point of view of thermal, electrical and mechanical part – it is the real – total effectiveness of the equipment - S2E module.
- For a customer, it is the most real and practical number. The parameters of steam are defined. Output of electrical power of the generator is according to calculation and we guarantee it .
- When the turbine operates with very low input parameters / for example : $p_1 = 4$ bar and $T_1 = 140$ C / - it is the subcritical flow of media from the jet - the module efficiency is 55%
- When the turbine operates at the level of the critical flow of media from the jet - it is module efficiency 55-60%
- At higher input parameters of the media is flow from the jet supercritical and in that case is total effectiveness of the module above 60%
- For the first calculations of the electrical output power we use the conservative calculation with efficiency of 55%
- Installed modules always get greater efficiency
- The electrical output power /with given parameters of media/, it is contractually guaranteed parameter and effectiveness , as a numerical Number – it is not so important .

Efficient alteration of the velocity head – test measurement datas - 95%

- Conversion of kinetic energy of media to the work in the turbine
- Parameter that mean the quality of technical solution of the jets and turbine

Other - partial efficiencies

- Efficiency of Generator - 93-95%
- Mechanical efficiency - 94%

Total mechanical efficiency - 94%

Total electrical efficiency - 95%

Total thermal efficiency 30 - 40%

- to the Mollier graph, overall heat efficiency is calculated from the zero values of steam
- including chimney, boiler and turbine efficiency
- Large - specially designed turbines 3 MWe and more have this efficiency cca 40-45% /

Application – Alternative to PRV

S2E Module is designed according to the reduction system parameters in order to provide the optimal electric power output.

Here are some examples of the possible applications based on the min/max parameters : p1, T1 /Steam Dryness, P2 and Q.

Company Name : Spirax Sarco UK

Contact person :

Date : 11.5.2011

	p1 / bar / abs	T1 / grad C / saturated	Dryness 1 %	p2 / bar / abs	T2 / grad C /	Dryness 2 %	Flow / V/hour /		entropy	enthalpy 1	enthalpy 2	ent1-ent2	enth. with eff. 55%	P / kWel	P / kwe /	MODUL SIZE	Modul Dimeters W x L x height / m /	Weight / kg /
Calculation 1	10	179,88	100	5	151,83	95,15	10		6,58	2777,12	2645,86	131,26	72,193	200,54	200	1 Pc Modul S2E 200	2,1 x 2,7 x 2,1	5 100
	10	179,88	95	5	151,83	90,51	10		6,36	2676,4	2548,117	128,283	70,55565	195,99	200	1 Pc Modul S2E 200	2,1 x 2,7 x 2,1	5 100
	10	179,88	90	5	151,83	86,27	10		6,14	2575,67	2458,87	116,8	64,24	178,44	180	1 Pc Modul S2E 180	2,1 x 2,7 x 2,1	5 100
Calculation 2	10	179,88	100	1	151,83	99,6	10		6,58	2777,12	2384,64	392,48	215,864	599,62	600	1 Pc Modul S2E 600	2,1 x 3,2 x 2,5	9 500
	10	179,88	95	1	151,83	83,5	10		6,36	2676,4	2302,63	373,77	205,5735	571,04	570	1 Pc Modul S2E 570	2,1 x 3,2 x 2,5	9 500
	10	179,88	90	1	151,83	79,67	10		6,14	2575,67	2220,63	355,04	195,272	542,42	545	1 Pc Modul S2E 545	2,1 x 3,2 x 2,5	9 500
Calculation 3	15	198,29	100	5	99,6	92,32	10		6,44	2791,01	2586,36	204,65	112,5575	312,66	315	1 Pc Modul S2E 315	2,1 x 3,2 x 2,5	9 500
	15	198,29	95	5	99,6	88,2	10		6,236	2693,69	2499,67	194,02	106,711	296,42	300	1 Pc Modul S2E 300	2,1 x 2,7 x 2,1	9 500
	15	198,29	90	5	99,6	84,06	10		6,03	2596,38	2412,12	184,26	101,343	281,51	280	1 Pc Modul S2E 280	2,1 x 2,7 x 2,1	9 500
Calculation 4	15	198,29	100	1	99,6	84,82	10		6,44	2791,01	2332,46	458,55	252,2025	700,56	700	1 Pc Modul S2E 700 SP	2,1 x 3,2 x 2,5	9 500
	15	198,29	95	1	99,6	81,46	10		6,236	2693,69	2256,41	437,28	240,504	668,07	670	1 Pc Modul S2E 670 SP	2,1 x 3,2 x 2,5	9 500
	15	198,29	90	1	99,6	78,05	10		6,03	2596,38	2179,62	416,76	229,218	636,72	630	1 Pc Modul S2E 630 SP	2,1 x 3,2 x 2,5	9 500
Calculation 5	20	212,38	100	5	151,83	90,2	10		6,339	2798,38	2543,44	254,94	140,217	389,49	390	1 Pc Modul S2E 390	2,1 x 3,2 x 2,5	9 500
	20	212,38	95	5	151,83	86,27	10		6,14	2703,89	2458,87	245,02	134,761	374,34	375	1 Pc Modul S2E 375	2,1 x 3,2 x 2,5	9 500
	20	212,38	90	5	151,83	82,24	10		5,94	2609,41	2373,87	235,54	129,547	359,85	360	1 Pc Modul S2E 360	2,1 x 3,2 x 2,5	9 500
Calculation 6	20	212,38	100	1	99,6	83,16	10		6,339	2798,38	2294,81	503,57	276,9635	769,34	770	1 Pc Modul S2E 770 SP	2,1 x 3,2 x 2,5	9 500
	20	212,38	95	1	99,6	79,67	10		6,14	2703,89	2220,62	483,27	265,7985	738,33	740	1 Pc Modul S2E 740 SP	2,1 x 3,2 x 2,5	9 500
	20	212,38	90	1	99,6	76,57	10		5,94	2609,41	2146,01	463,4	254,87	707,97	710	1 Pc Modul S2E 710 SP	2,1 x 3,2 x 2,5	9 500

Input parameters :
Output parameters :
Flow :

p1, T1
p2, T2
steam flow

Dryness in % :

100 % it is saturated steam
less than 100% it is wet steam

S2E turbine can be operated in wet S2E turbine can be operated in wet steam conditions

enthalpy 1 :

↑point 1 / Mollier diagram/

enthalpy 2 :

↑point 2 / Mollier diagram /

enth1 - enth2 :

enthalpy difference - teoretical work

enth with eff. 55% :

for the first calculation we use effi for the first calculation we use efficiency 55 %
efficiency of our moduls in operatic efficiency of our moduls in operations are better

P calculated :

calculated Power

P :

Modul S2E power

Modul S2E :

Modul S2E size

..... SP = special

TECHNOPA GmbH, Hietzinger Hauptstr. 50 1130 Vienna, Austria

tel.:+43 1 877 0553 • fax: +43 1 877 8446 • www.technopa.eu • office@technopa.eu